

Automatic riveting machine

GAV 8000 eco

Fully-automatic blind rivet processing system and cost-optimised variant of the GAV 8000 electronic without setting process monitoring

Working range

- Blind rivets up from 2.4 mm to 6.4 mm Ø alu and copper
- Blind rivets up to 6 mm Ø steel
- Blind rivets up to 5 mm Ø stainless steel
- Blind rivets up to flange diameter 11.4 mm
- Rivet body lengths above 30 mm
- Traction power up to 11,770 N at 6-7 bar air pressure

Productivity and savings potential

- Up to 40 blind rivets can be processed every minute
- No trained personnel required for operation
- Can be easily integrated into fully-automatic production systems

System description

- Electronic system controls
- Intuitive menu guidance via navigation and function keys
- Function display
- Maintenance display and simple fault diagnosis
- Customer-specific software modification is possible
- Ideal for applications that do not require any process monitoring
- Rivet mandrels are disposed of via a vacuum system
- Surface contact trigger available as an optional extra
- Can be integrated into the system or operated independently
- Interface for external memory-programmable control system (SPS) can be realised via the GESIPA®-Interface



Advice and delivery time on request

Subsequent upgrade to GAV 8000 electronic possible in our Walldorf factory at extra price



Pistol versions for GAV 8000 eco and GAV 8000 electronic



Specific workstation configuration

For all GAV versions, three different setting pistol variants are available for the ideal configuration of the workstation.

For manual workstations, pistols are available as overhead versions with overhead hose assembly or standard pistols with floor-mounted hose assembly. Both versions are equipped with a balancer to ensure fatigue-free working. The robotic pistol has been developed exclusively for use in fully automatic production systems or robot-controlled systems. It is supplied from stock with corresponding drilled holes for easy installation. For further questions, please contact our Technical Sales team.

A setting pistol suitable for your application is supplied at time of delivery.

Standard pistol

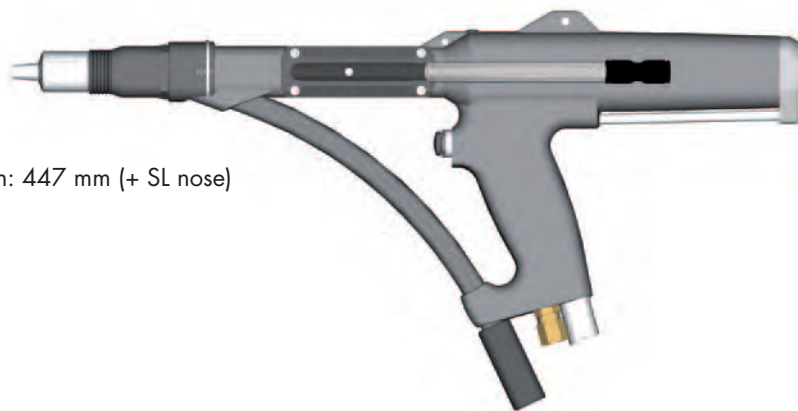

Total length: 447 mm (+ SL nose)

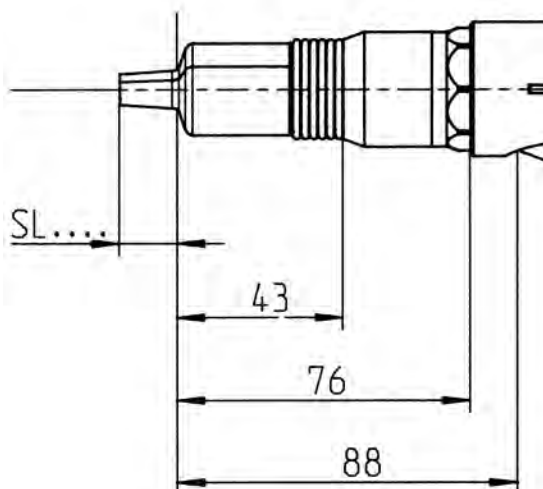
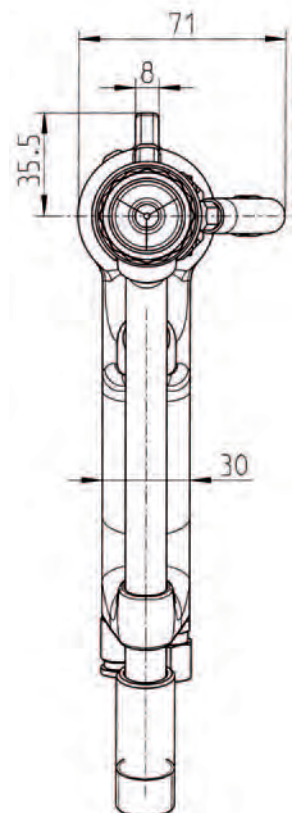

The standard pistol is primarily used for manual operator-controlled use.

The advantages

- Can be used for vertical and horizontal riveting
- Inexpensive variant
- On request, it can be fitted with an extra handle to improve ergonomics, in particular for applications involving vertical riveting.

All drawing sizes in mm

The experts in blind riveting

Overhead pistols

Total length: 447 mm (+ SL nose)

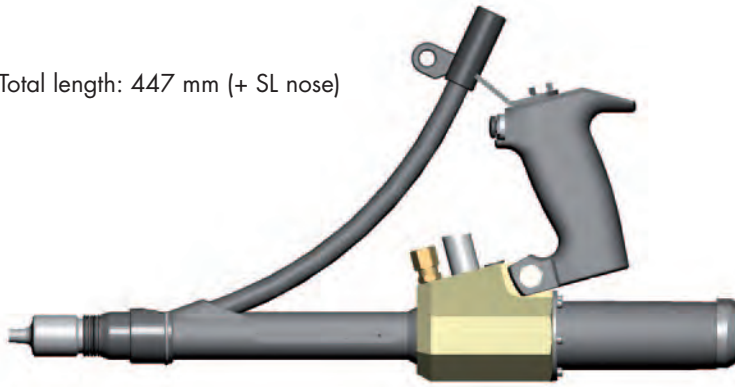

The overhead pistol can be used everywhere where the hose package is cumbersome or where it could come into contact with sensitive surfaces.

The advantage:

- Available with contact pressure monitoring

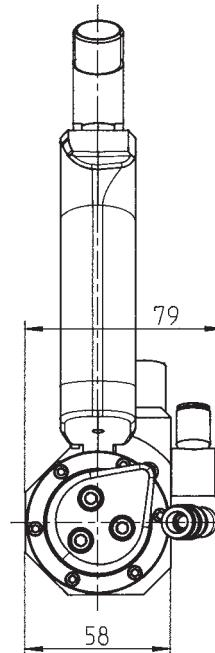
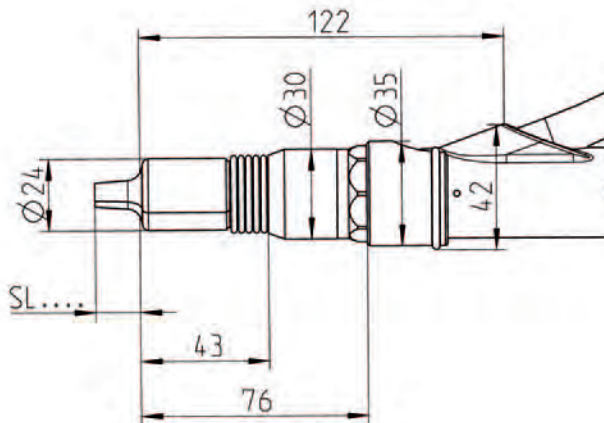

All drawing sizes in mm

Robotic pistol

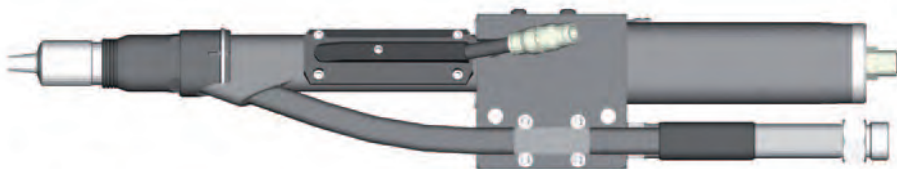

Total length: 441 mm (+ SL nose)

The robotic pistol has been developed primarily for use in fully automatic production applications/system (linear units/robots).

The advantages

- Ideal for integration in a production system
- On request, it can also be fitted with an extra handle (with trigger button) for vertical riveting so that it can be used manually.

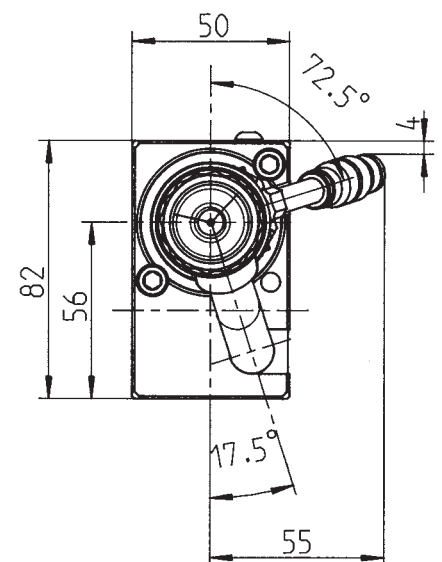
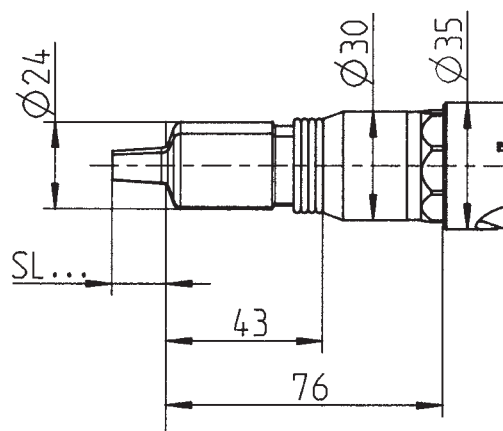
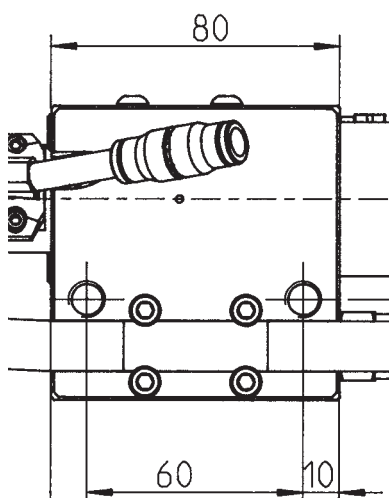

All drawing sizes in mm

Accessories for GAV 8000 (both versions)

The accessories for GAV 8000 eco and GAV 8000 electronic allow an individual system configuration for each different application case

Interface for connection to external control

As an in-house development by GESIPA®, the GESIPA®-Interface 16 has digital inputs and outputs for controlling, a card writer for processing data and a USB slot for fast data transmission.

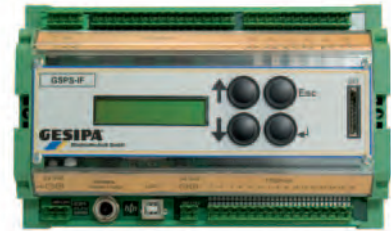

GESIPA® interface

GAV carriage

The trolley that has been specially designed for the GAV enables it to be mobile thereby allowing the workplace to be changed quickly and easily.

Foot pedal

The foot pedal is a good solution wherever applications require both hands to affix the parts that need to be riveted.



Foot pedal

Special length tube packages

A larger working radius can be achieved, e.g. for use on fully automatic production lines, by using packages of special hose lengths. These are available in various dimensions between 3.75 m and 5.0 m to meet the requirements of the various applications.

Comparison of GAV 8000 eco and GAV 8000 electronic

Properties	GAV 8000 eco	GAV 8000 electronic
Range of possible sizes 2.4 mm - 6.4 mm (Alu)	x	x
up to 40 rivet settings per min.	x	x
Independent system operation possible	x	x
PLC control possible	x	x
Intelligent control - excellent process safety	x	x
Setting of all operating parameters via the display	x	x
Customer-specific software modification	x	x
Maintenance display	x	x
Process monitoring		x
Process parameter memory for up to 9,999 different parts		x
Online transfer of the process data		x
The last 2 million rivet processes are saved in the device		x

The practical modular principle guarantees efficiency and quality

Individual concept for efficiency and flexibility

GESIPA®'s fully-automatic blind rivet processing systems are constructed to meet the customer's special production environment. All factors, such as workplace design, production type, application, securing of flawless work processes, integration into the sequential organisation and also process documentation for safety-relevant parts, are taken into consideration.

GAV are therefore available with various pistol models, hose length packages, special accessories for various rivet dimensions and production requirements.

This results in a large variety of models and a high level of efficiency thanks to the solutions that are adapted to meet requirements.

The GAV can be integrated into the system or operated independently. If the application changes, the system can be quickly and easily adapted to the new environment.

GAV 8000 – use in robot applications

Use by industry in robot-controlled applications

Both versions of the GAV 8000 can be integrated into robot systems. Industrial robots are used almost everywhere in the production environment. They can be programmed to carry out various movements and can therefore be used highly efficiently in combination with the GESIPA® rivet equipment.

With the controlled, fast and secure production processes it is possible to achieve the following benefits by using a fully-automatic GAV combined with a multi-axle robot:

- First rate precision
- High efficiency
- Short cycle times
- High flexibility



Blind rivet function documentation and setting process monitoring

The integrated GESIPA® quality management system guarantees precision and accuracy right from the very first production step through to the processed blind rivet.

The combination of the use of function-documented blind rivets and the use of the setting process monitoring function of the GAV 8000 electronic guarantees process-secure connections.

The quality management system comprises of three areas:

- Dimensional review
- Function test
- Setting process monitoring

The dimensional review and the function test are carried out at GESIPA®, whilst the setting process is monitored during the riveting process at the customer's premises.

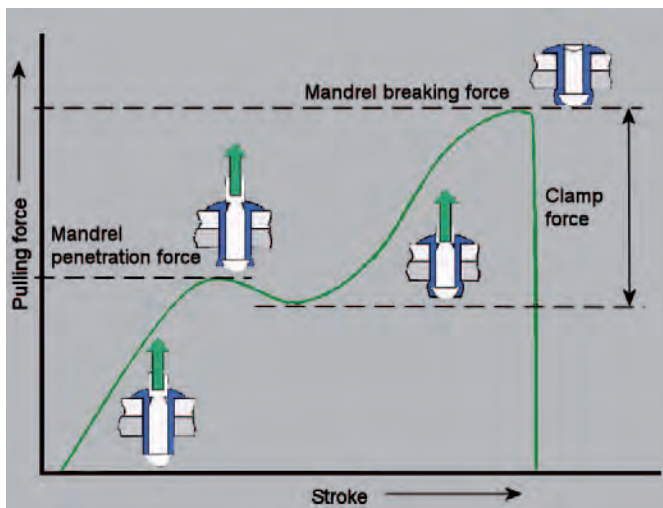

Function-documentation / setting curve

In addition to other parameters, the setting curve is measured using calibrated testing equipment for every batch of application-specific blind riveting. The measuring results of the shaft deformation, slip-in behaviour, mandrel break load and torque are compared to target values to ensure that the blind rivet in the application is deformed as required and creates a secure connection.

Function documentation / mandrel ejection force

The remaining part of the mandrel enclosed in the set rivet is pressed out with the aid of a needle. The measured force can be used to determine whether the remaining part of the pin is properly locked and will not cause any rattling noises or fall out. The batch is only released if both these values are within tolerances.

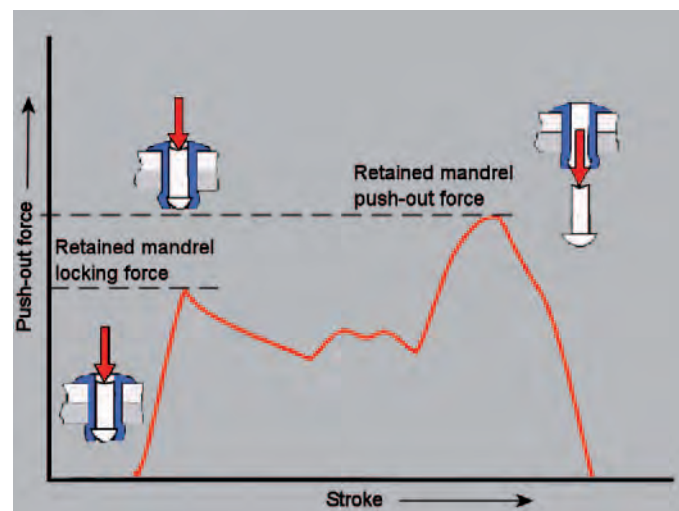

Monitored process – reliable connection

100% inspections of the riveting processes are required for safety-relevant applications for industrial processing of blind rivets. In this case, the fully-automatic rivet device GAV 8000 electronic allows application-compatible efficient solutions ranging from the basic system through to a system with a barcode scanner.

The concept of the integrated setting process monitoring

The process monitoring system is an integral part of the GAV 8000 electronic. It offers the following benefits:

- Optimum process security thanks to integrated quality concept
- Blind rivet-specific process monitoring
- System can be operated independently
- No memory-programmable control system (SPS) required to operate the device
- No system calibration required when system is exchanged
- Little installation effort required
- Interfaces to the control integration



Display of a GAV 8000 electronic indicating the setting curve as part of the setting process monitoring

Programming the setting process monitoring

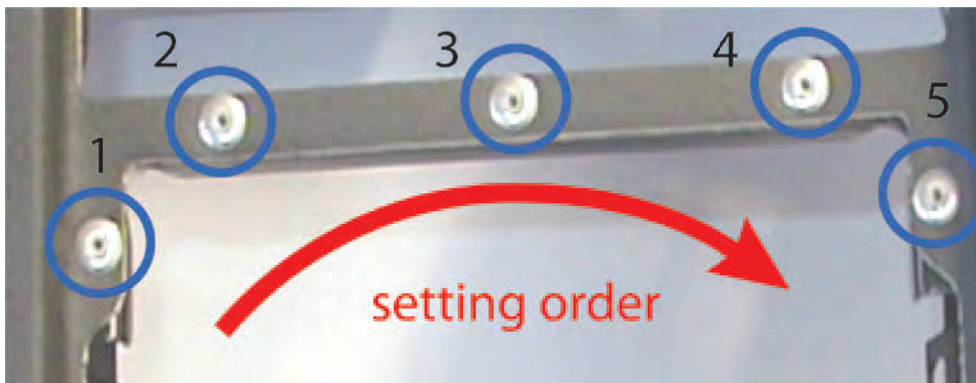

The setting sequence

Step 1: Setting up blind rivet position-specific profiles

Recording and archiving of the relevant process parameters to create a blind rivet connection with reference process curves after defining the analysis window

Step 2: Generation of part-specific profile lists

Summary of the profile in the setting sequence as a control file for the process sequence and process assessment

Step 3: Operating the device

Online analysis and saving of the setting process data with process interruption if deviations are detected