

# AccuBird®



## AccuBird® – Reliability

- Electronic control
- No mechanical switching components
- Electronic temperature and overload protection
- High reliability through low loss power transmission via a highly efficient ball screw drive

## AccuBird® – Freedom

Cablefree tool for flexible operation in installation jobs and industry production

## AccuBird® – High performance

- High pulling force for safe setting of blind rivets up to 5 mm diameter in all materials
- High yield per battery charge
- Large 20mm stroke

## AccuBird® – Versatility

Blind rivets up to 5 mm Ø all materials. BULB-TITE® blind rivets 4 mm; 5.2 and 6.3 mm Ø alu and steel



AccuBird® with battery 14.4 V / 1.3 Ah, and charger in carrying case

**Part no. 725 0037**

AccuBird® with two batteries 14.4 V / 1.3 Ah, and charger in carrying case

**Part no. 725 0019**

AccuBird® with battery 14.4 V / 1.3 Ah, and charger in cardboard box

**Part no. 725 0029**

AccuBird® with battery 14.4 V / 1.3 Ah, in cardboard box

**Part no. 725 0010**

AccuBird® with battery 14.4 V / 1.3 Ah, and charger with spring loaded trigger system in carrying case

**Part no. 725 0015**

## AccuBird® – with Li-Ion energy

- Choice of 1.3 Ah and 2.6 Ah Li-Ion batteries

## AccuBird® – High speed

- High speed of operation through automatic resetting of the jaw mechanism immediately after each setting process

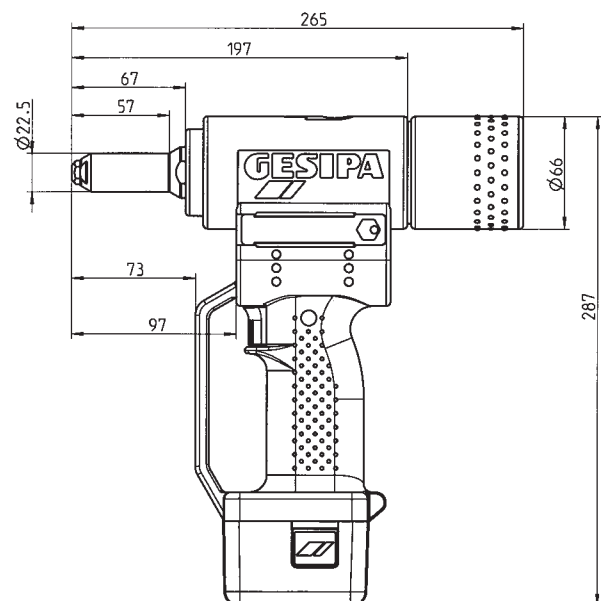

# Rechargeable 14.4 Volt riveting tool with Li-Ion battery

## Working range

Sets blind rivets up to 5 mm Ø all materials. BULB-TITE® blind rivets 4 mm; 5.2 and 6.3 mm Ø alu and steel

## Nosepieces / accessories

Nosepieces: 17/24, 17/27, 17/29 and 17/32

## Technical data

Weight: 2.0 kg with battery  
 Stroke: 20 mm  
 Drive: DC motor  
 Traction power: 10,000 N

## Jaws (3 parts)

Part no. 725 1613

## Nosepiece - power per battery charge

Blind rivet Ø in mm	Material	approx. pc/ battery charge	Nosepiece	Part no.
2.4	Alu	1,500	17/18*	725 2075
3.2	CAP-Alu, CAP-Cu	1,000	17/18*	725 2075
3 and 3.2	Alu	800	17/24	725 1583
3 and 3.2	Steel	800	17/24	725 1583
3 and 3.2	Stainless steel	800	17/24	725 1583
4	Alu	800	17/24	725 1583
4	Steel	700	17/27	725 2040
4	Stainless steel	640	17/29	725 2059
4.8 and 5	Alu	550	17/29	725 2059
4.8 and 5	Steel	420	17/32	725 2067
4.8 and 5	Stainless steel	320	17/36*	725 2083
6	Alu	240	17/36*	725 2083

Special nosepieces are available on request

BULB-TITE® blind rivet Ø in mm	Material	approx. pc/ battery charge	Nosepiece	Part no.
4	Alu	1,000	17/26 BT*	725 2202
5.2	Alu	800	17/32 BT*	725 2210
6.3	Alu	600	17/42 BT*	725 2229
6.3	Steel	300	17/42 BT*	725 2229

\* Available as special accessory



**Universal nosepiece – 17**  
To suit AccuBird®

Part no. 725 1637

Detailed information can be found on page 85

## Special accessory: Retaining nosepiece

- Inserted rivet remains in any position
- Rivets may be set with only one hand
- Safer working

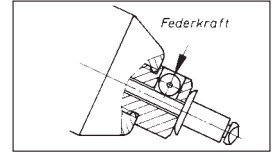

Retaining nose-piece	Part no.	Retaining nose-piece	Part no.
17/18 R	725 4078	17/29 R	725 4108
17/24 R	725 4086	17/32 R*	725 4116
17/27 R	725 4094	17/36 R*	725 4124

\*also for PowerBird®

**Changeover set (Part 50) for BULB-TITE® blind rivet:**  
Part 54 (jaw pusher), Part 55 (jaws) and 3 nosepieces  
Part no. 725 9290

## Charger 14.4 V Li-Ion

Part no. 725 1134



## Technical data

Input voltage: 230 V / 50 Hz  
 Output voltage: 14.4 V DC  
 Recharging time: 50 to 100 minutes (battery depending)  
 Weight: 0.6 kg

## Battery

**14.4 V/1.3 Ah (Li-Ion)**  
Part no. 725 1045

Weight: 0.35 kg

## Power battery

**14.4 V/2.6 Ah (Li-Ion)**  
Part no. 725 1049

Available as special accessory  
Weight: 0.5 kg



**Charger 12 V NiCd**  
Part no. 725 1035

**Extended spent mandrel container**  
to suit AccuBird® and PowerBird®  
Part no. 725 9328

# PowerBird®



## PowerBird® – Innovation

As a stronger brother to the well-known AccuBird® the PowerBird® is the powerful extension of the so-called "Bird family" from GESIPA® able to cope with all high structure blind rivets.

## PowerBird® – Practical aspects

- User oriented scope of delivery: metal carrying case with one battery charger, one battery and four nosepieces

## PowerBird® – Economy

- Good price-performance ratio
- Large working range
- Short processing times
- High service life thanks to 2.6 Ah power battery

## PowerBird® – With Li-Ion energy

- 2.6 Ah battery, alternatively 1.3 Ah on request



PowerBird® with power battery 14.4 Volt / 2.6 Ah and charger, in carrying case,

**Part no. 724 0031**

PowerBird® with two power batteries 14.4 Volt / 2.6 Ah and charger, in carrying case,

**Part no. 724 0040**

PowerBird® with power battery 14.4 Volt / 2.6 Ah and charger, in carrying case with spring loaded trigger system

**Part no. 724 0160**

## PowerBird® – Versatility

Blind rivets from 4.8 mm Ø steel, up to 6.4 mm Ø all materials and up to 8 mm alu, except G-Bulb® Ø 6.4 mm. Bulb-tite® blind rivets up to 7.7 mm Ø all materials. Mega Grip® blind rivets up to 6.4 mm Ø all materials.

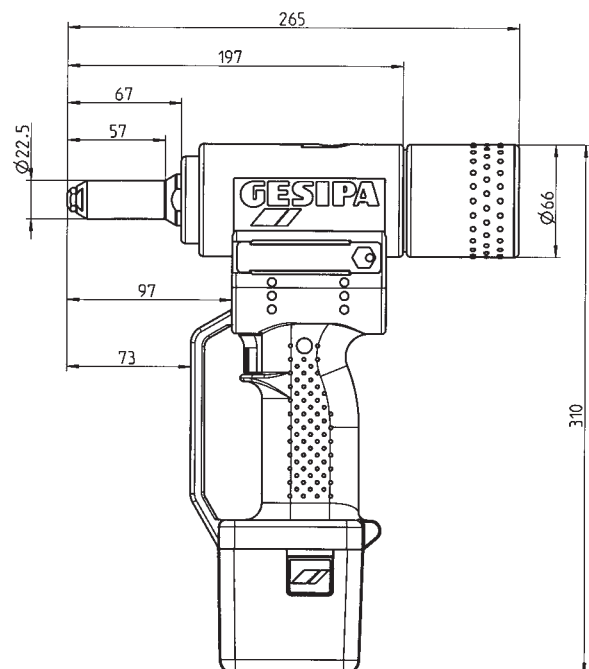

# Rechargeable 14.4 volt power battery riveting tool with Li-Ion battery for even higher performance

## Working range

Blind rivets from 4.8 mm Ø steel, up to 8 mm Ø alu and up to 6.4 mm all materials, except G-Bulb® Ø 6.4 mm. BULB-TITE® blind rivets up to 7.7 mm Ø all materials. MEGA GRIP® blind rivets up to 6.4 mm Ø all materials.

## Technical data

Weight: 2.2kg with battery  
 Stroke: 20 mm  
 Drive: DC motor  
 Traction power: 14,000 N

## Nosepieces / accessories

Nosepieces: 17/32, 17/36, 17/40 and 17/45

## Jaws (3 parts)

Part no. 710 2208

## Nosepiece - power per battery charge

Rivet Ø mm	Rivet material	approx. pc/battery charge	Nosepiece	Part no.
4.8 and 5.0	Steel, Alu	700	17/32	725 2067
4.8 and 5.0	Stainless steel	560	17/36	725 2083
6.0	Alu	560	17/36	725 2083
6.0	Steel	300	17/40	725 2560
6.4	Alu, PG-Alu	420	17/45	724 3065
6.4	Steel	250	17/45	724 3065
8	Alu	350	17/45	724 3065

## BULB-TITE® blind rivet

4.0	Alu	1,000	17/26 BT*	725 2202
5.2	Alu	900	17/32 BT*	725 2210
6.3	Alu	590	17/42 BT*	725 2229
6.3	Steel	310	17/42 BT*	725 2229
6.3	Monel	380	17/42 BT*	725 2229
7.7	Alu	470	17/48 BT*	725 2237
			and jaws	715 1527

## MEGA GRIP® blind rivet

4.8	Alu	600	17/31 MG*	725 2250
6.4	Alu	420	17/41 MG*	724 3146
4.8	Steel	420	17/31 MG*	725 2250
6.4	Steel	150	17/41 MG*	724 3146
4.8	Stainless steel	420	17/31 MG*	725 2250
6.4	Stainless steel	150	17/41 MG*	724 3146

\* Available as special accessory  
 Special design nosepieces are available on request



The experts in blind riveting

## Special accessory: Retaining nosepiece

- Inserted rivet remains in any position
- Rivets may be set with only one hand
- Safer work

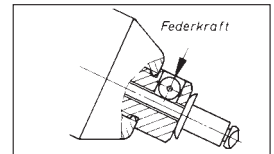

Retaining nosepiece	Part no.	Retaining nosepiece	Part no.
17/40 R	725 4125	17/45 R	725 4126

## Charger 14.4 V Li-Ion

Part no. 725 1134



## Technical data

Input voltage: 230 V / 50 Hz  
 Output voltage: 14.4 V DC  
 Recharging time: 50 to 100 minutes (battery depending)  
 Weight: 0.6 g

## Battery

14.4 V/1.3 Ah (Li-Ion)

Part no. 725 1045

Available as special accessory

Weight: 0.35 g

## Power battery

14.4 V/2.6 Ah (Li-Ion)

Part no. 725 1049

Weight: 0.5 g



## Charger 12 V NiCd

Part no. 725 1035

One-piece, slim extension unit to approx. 110 mm, Ø 22.5 mm, for setting rivets in deep positions and with difficult access  
 Part no. 724 2054

One-piece, slim extension unit to approx. 160 mm, Ø 22.5 mm, for setting rivets in deep positions and with difficult access  
 Part no. 724 2055

Further dimensions available upon request

# PowerBird® Solar

**Special design for solar applications**  
**Ideal for deep, difficult to access areas**

## Working range

Blind rivets from 4.8 mm Ø steel and up to 6.4 mm all materials, except G-Bulb® Ø 6.4 mm.  
BULB-TITE® blind rivets up to 7.7 mm Ø all materials.  
MEGA GRIP® blind rivets up to 6.4 mm Ø all materials.

## Technical data

Weight:	2.36 kg with battery
Stroke:	20 mm
Drive:	DC motor
Traction power:	14,000 N
Extension unit:	approx. 160 mm

## Nosepieces / accessories

approx. overall length 160 mm extension  
two Li-Ion power batteries 2.6 Ah/14.4 V  
Quick charger  
Nosepieces 17/32, 17/36, 17/40, 17/45, and 17/48 BT  
Plastic carrying case



**Part no. 724 0041**

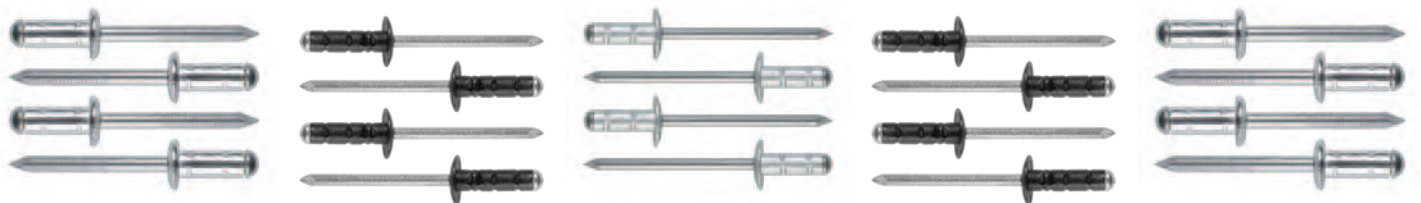

**The GESIPA® SolarGrip® blind rivet program can be found on page 30.**

# PowerBird® Gold Edition

**The exclusive Gold Edition  
with 18,000 N traction power**

## Strong - stronger – PowerBird® Gold Edition

PowerBird®, the all-rounder of the Bird family by GESIPA® with its wide range of application possibilities, is now available in an even stronger version: with a setting force of 18.000 N it can even set G-Bulb® and PolyGrip® blind rivets up to a diameter of 6.4 mm of all materials.

## Practical - even more practical – PowerBird® Gold Edition

- Fatigue-free working through well balanced weight repartition and ergonomic grip
- Gravity controlled evacuation of spent mandrels: forward through the nosepiece or backwards into the mandrel container
- The immediate and automatic reset after each riveting process saves energy and speeds up the operation
- Exchange nosepieces and wrench always included in the tool eliminate work interruptions
- Compact, shockproof tool housing for all application conditions
- User oriented scope of delivery: plastic carrying case with one battery charger, one battery and four nosepieces (17/32, 17/36, 17/40, 17/45)

## Nosepiece - power per battery charge

### BULB-TITE®, PolyGrip®, G-Bulb® and standard blind rivet

Blind rivet Ø in mm	Material	approx. pc/battery charge	Nose- piece	Part no.
4.8 and 5.0	Steel, Alu	<b>700</b>	17/32	<b>725 2067</b>
4.8 and 5.0	Stainless steel, Stinox, PG- steel, PG stainless steel	<b>560</b>	17/36	<b>725 2083</b>
6.0	Alu	<b>560</b>	17/36	<b>725 2083</b>
6.0	Steel	<b>300</b>	17/40	<b>725 2560</b>
6.4	Alu	<b>420</b>	17/40	<b>725 2560</b>
6.4	Steel, PG-steel, Alu/alu, Stainless steel	<b>250</b>	17/45	<b>724 3065</b>
8	Alu	<b>350</b>	17/45	<b>724 3065</b>

### G-Bulb® Blind rivet

4.8	Steel/steel	<b>530</b>	17/32	<b>725 2067</b>
6.4	Steel/steel	<b>390</b>	17/45	<b>724 3065</b>
4.8	Stainless steel/stainless steel	<b>470</b>	17/32	<b>725 2067</b>
6.4	Stainless steel/stainless steel	<b>390</b>	17/45	<b>724 3065</b>

### MEGA GRIP® blind rivet

4.8	Alu	<b>600</b>	17/31 MG*	<b>725 2250</b>
6.4	Alu	<b>420</b>	17/41 MG*	<b>724 3146</b>
4.8	Steel	<b>420</b>	17/31 MG*	<b>725 2250</b>
6.4	Steel	<b>150</b>	17/41 MG*	<b>724 3146</b>
4.8	Stainless steel	<b>420</b>	17/31 MG*	<b>724 2250</b>
6.4	Stainless steel	<b>150</b>	17/41 MG*	<b>724 3146</b>

### BULB-TITE® blind rivet

4.0	Alu	<b>1,000</b>	17/26 BT*	<b>725 2202</b>
5.2	Alu	<b>900</b>	17/32 BT*	<b>725 2210</b>
6.3	Alu	<b>590</b>	17/42 BT*	<b>725 2229</b>
6.3	Steel	<b>310</b>	17/42 BT*	<b>725 2229</b>
6.3	Monel/stainless steel	<b>380</b>	17/42 BT*	<b>725 2229</b>
7.7	Alu	<b>470</b>	17/48 BT*	<b>725 2237</b>
			and jaws*	<b>715 1527</b>

\* Available as special accessory. Special design nosepieces are available on request

**The experts in blind riveting**



## The all-round talent – PowerBird® Gold Edition

Processes blind rivets from Ø 4.8 mm steel to Ø 6.4 mm all materials, BULB-TITE® blind rivets up to Ø 7.7 mm, all materials, MEGA GRIP® blind rivets up to Ø 6.6 mm alu and steel, G-Bulb® blind rivets up to Ø 6.4 mm all materials, PolyGrip® blind rivet up to Ø 6.4 mm all materials.

## PowerBird® Gold Edition – Technical data

Traction power: 18,000  
Weight (incl.  
power battery): 2.2 kg  
Drive:  
DC motor  
Working stroke: 20 mm



### PowerBird® Gold Edition

with power battery 14.4 Volt / 2.6 Ah and charger, in plastic carrying case,  
**Part no. 724 0001**

### PowerBird® Gold Edition with spring loaded trigger system

with power battery 14.4 Volt / 2.6 Ah and charger, in plastic carrying case,  
**Part no. 724 0002**

Jaws (3 parts) for PowerBird® Gold Edition  
**Part no. 710 2208**