

TAURUS series

Pneumatic-



TAURUS 1

Part no. 756 0001

Working range

Blind rivets from 2.4 to 3.2 mm Ø all materials and up to 4 mm Ø alu/steel (max. mandrel dia. 2.5 mm)

Technical data

Weight:	1.3 g
Operating air pressure:	5-7 bar
Air hose connection:	6 mm Ø (1/4")
Air consumption:	approx. 1.0 ltr. per rivet
Traction power:	4,200 N at 5 bar
Stroke:	15 mm

Nosepieces / accessories

Nosepieces
17/18, 17/24 and 17/27
Maintenance wrench SW12/14, SW14/17
1 hydraulic oil bottle 100 ml
1 oil refill can
Operating instructions with spare parts list

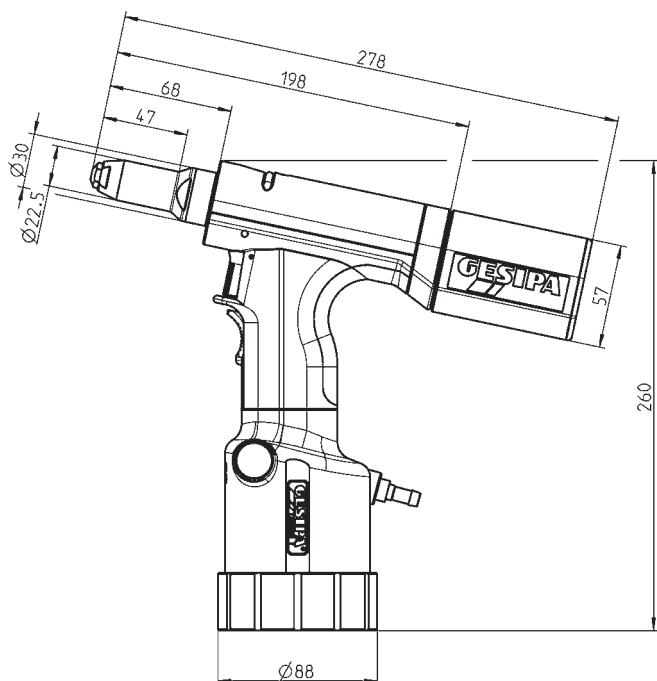

TAURUS 2

Part no. 757 0007

Working range

Blind rivets up to 5 mm Ø all materials and up to 6 mm Ø alu/steel (max. mandrel Ø 3.2 mm)

Technical data

Weight:	1.6 g
Operating air pressure:	5-7 bar
Air hose connection:	6 mm Ø (1/4")
Air consumption:	approx. 2.3 ltr. per rivet
Traction power:	9,000 N at 5 bar
Stroke:	18 mm

Nosepieces / accessories

Nosepieces
17/27, 17/29 und 17/32 und 17/36
Maintenance wrench SW12/14, SW14/17
1 hydraulic oil bottle 100 ml
1 oil refill can
Operating instructions with spare parts list

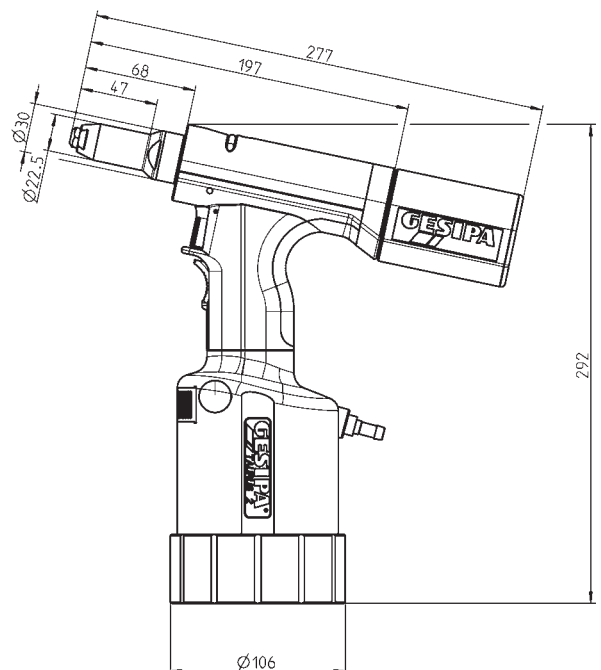

hydraulic blind rivet setting tools



TAURUS 3

Part no. 758 0002

Working range

Blind rivets up to 6.4 mm Ø all materials
(max. mandrel Ø 4.5 mm)

Technical data

Weight:	1.9 g
Operating air pressure:	5-7 bar
Air hose connection:	6 mm Ø (1/4")
Air consumption:	approx. 4.8 ltr. per rivet
Traction power:	14,000 N at 5 bar
Stroke:	25 mm

Nosepieces / accessories

Nosepieces
17/36, 17/40 und 17/45
Maintenance wrench SW12/14, SW14/17
1 hydraulic oil bottle 100 ml
1 oil refill can
Operating instructions with spare parts list

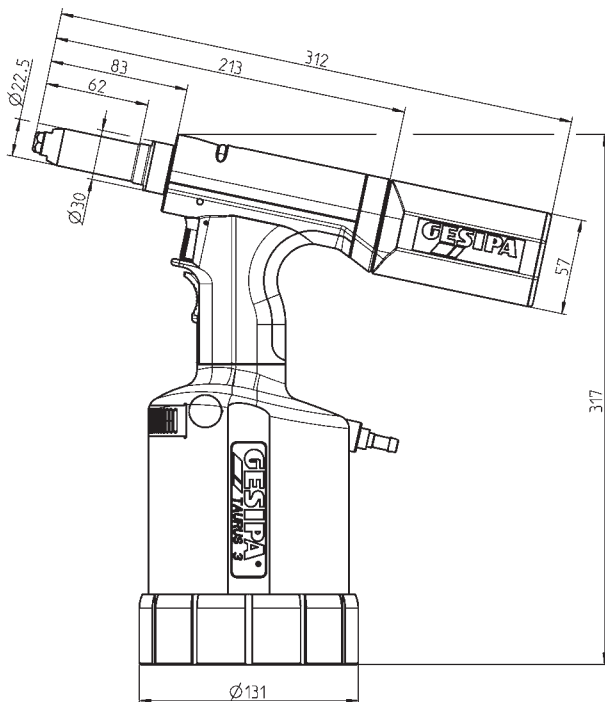

TAURUS 4

Part no. 759 0001

Working range

Blind rivets up to 6.4 mm Ø all materials
and up to 8 mm Ø alu (max. mandrel Ø 4.5 mm)

Technical data

Weight:	2.0 g
Operating air pressure:	5-7 bar
Air hose connection:	6 mm Ø (1/4")
Air consumption:	approx. 4.8 ltr. per rivet
Traction power:	20,000 N at 5 bar
Stroke:	19 mm

Nosepieces / accessories

Nosepieces
17/36, 17/40 and 17/45
Maintenance wrench SW12/14, SW14/17
1 hydraulic oil bottle 100 ml
1 oil refill can
Operating instructions with spare parts list

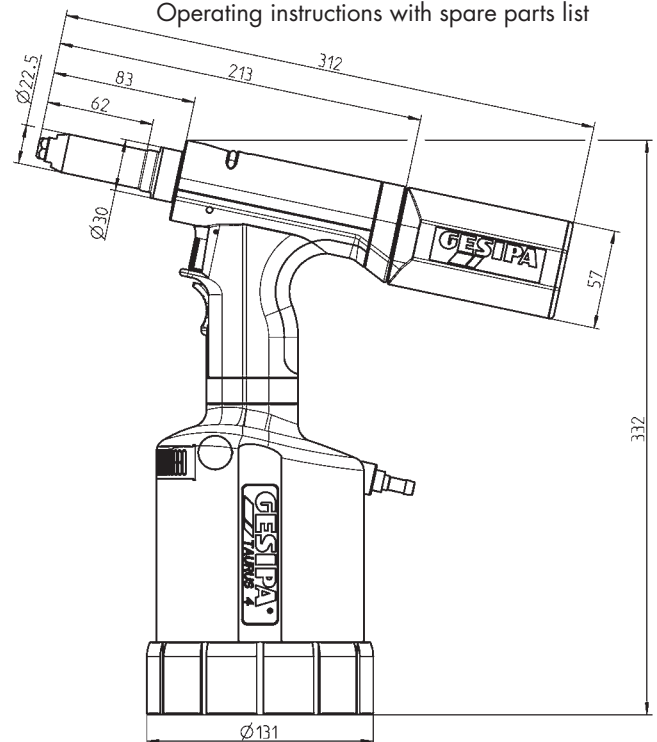

TAURUS series

Pneumatic-



TAURUS 5

Basic tool
Part no. 760 0001

Working range

Blind rivets above 6.4 mm Ø all materials and lockbolts up to 10 mm Ø with corresponding pulling heads

Technical data

Weight: 3.4 g
Operating air pressure: 5-7 bar
Air hose connection: 6 mm Ø (1/4")
Air consumption: approx. 6.9 ltr. per rivet
Traction power: 42,000 N at 7 bar
Stroke: 17 mm

Nosepieces / accessories

1 hydraulic oil bottle 100 ml
1 oil refill can
Operating instructions with spare parts list

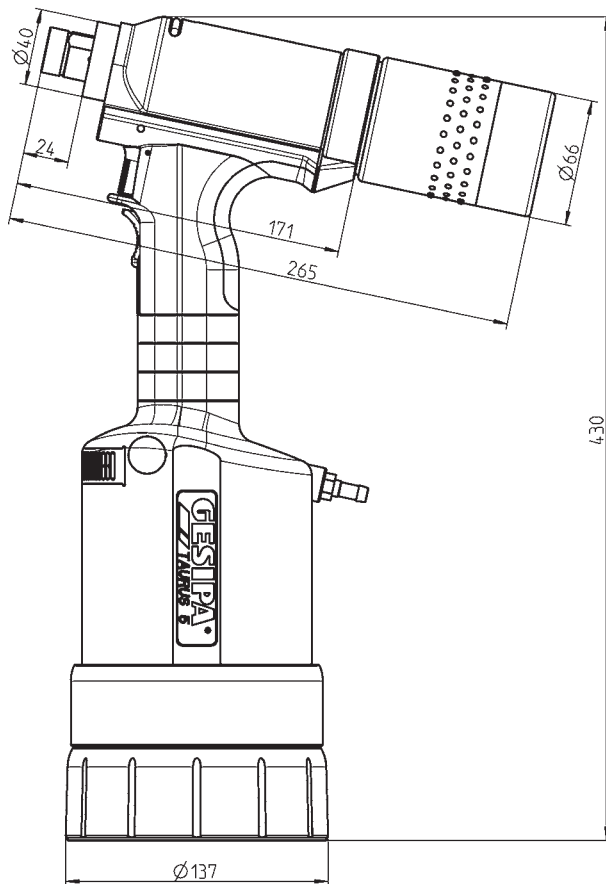

TAURUS 6

Basic tool
Part no. 761 0002

Working range

Blind rivets above 6.4 mm Ø all materials and lockbolts up to 10 mm Ø with corresponding pulling heads

Technical data

Weight: 3.4 g
Operating air pressure: 5-7 bar
Air hose connection: 6 mm Ø (1/4")
Air consumption: approx. 6.9 ltr. per rivet
Traction power: 50,000 N at 7 bar
Stroke: 15 mm

Nosepieces / accessories

1 hydraulic oil bottle 100 ml
1 oil refill can
Operating instructions with spare parts list

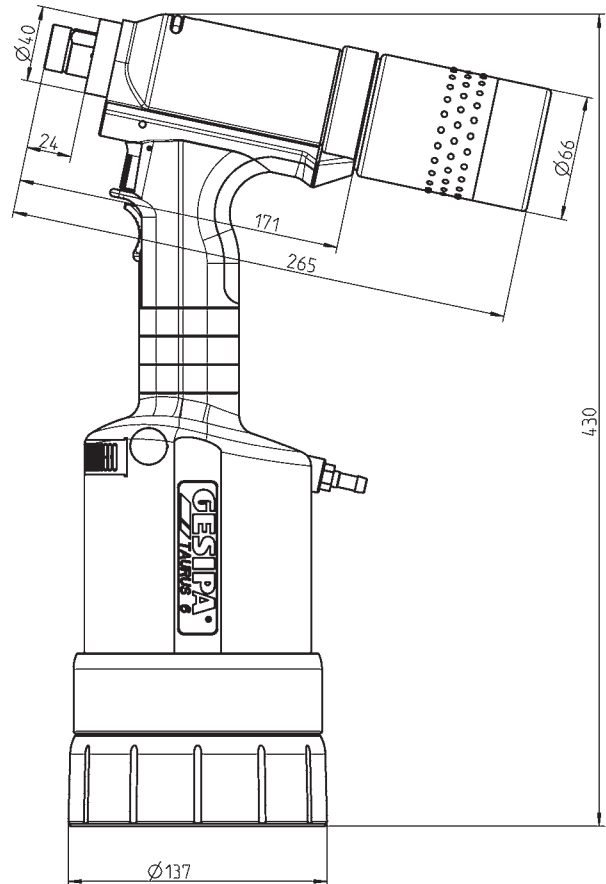

TAURUS 5 and 6 need to be fitted with nosepieces to match the application.
Will be produced on request.